



# DOUGH DIVIDER & ROUNDER



**Semi-Automatic Dough Divider/Rounder, Available in 15, 22, 30, 36 & 54 Portions, Includes (3) Sanitary Plastic Rounding Plates, Stainless Steel Cutting Blades, Wheel Mounted, Interchangeable Dough Head, ETL**



PROJECT \_\_\_\_\_

ITEM NO. \_\_\_\_\_

NOTES \_\_\_\_\_

MODEL NUMBER: **DSA315, DSA322, DSA330, DSA336, DSA354**



**FEATURES**

- Semi-Automatic Dough Cutting & Rounding
- Portion Size Dependent Upon Dough Plates (reference table below)
- Variance of Individual Portion Weight is Subject to Change Dependent on Dough Formulation and Proper Operation of Unit
- Hourly Production up to 1,200 Pieces (depending on operator and workflow)
- Sanitary Dough Press Head
- Three (3) Sanitary Rounding Plates Included
- Divides Dough with an Optimal Absorption Ratio from 55-65% (dependent on dough formulation)
- Easy Snap On and Off Head Cover for Easy Cleaning
- Self-Lubricating

**CONSTRUCTION**

- Stainless Steel Cutting Knives
- Wheel Mounted
- 6' Power Cord
- Stainless Steel Feet to Prevent Rusting
- Anti-Vibration Pad for Quiet Operation

**OPTIONS & ACCESSORIES**

- Stainless Steel Construction [Suffix I]
- Additional Press Heads (DSAHXX)
- Additional Dough Plates
  - DSA315: FMF550A
  - DSA322: FMF551A
  - DSA330: FMF553A
  - DSA336: FMF558A
  - DSA354: FMF559

**WARRANTY**

- One Year Labor & Two Year Parts

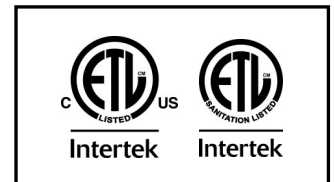

Model	Weight	Overall Dimensions			Portions	Portion Weight	
		W	D	H (without handle)		Min.	Max.
DSA315	628 (285)	24 7/16" (621)	26" (660)	52 3/8" (1330)	15	2.1 (60)	7 (200)
DSA322	628 (285)	24 7/16" (621)	26" (660)	52 3/8" (1330)	22	1.4 (40)	4.8 (135)
DSA330	628 (285)	24 7/16" (621)	26" (660)	52 3/8" (1330)	30	1 (30)	3.5 (100)
DSA336	628 (285)	24 7/16" (621)	26" (660)	52 3/8" (1330)	36	0.88 (25)	2.3 (66)
DSA354	628 (285)	24 7/16" (621)	26" (660)	52 3/8" (1330)	54	0.5 (15)	1.4 (40)

SPECIFICATIONS SUBJECT TO CHANGE WITHOUT NOTICE

KCL & REVIT DRAWINGS UPON REQUEST

REVISION C | 5/18/23

Follow Us



Doyon

5600 13th Street, Menominee, MI 49858

906.863.4401 | 800.338.9886 | www.doyon.qc.ca





PROJECT \_\_\_\_\_  
 ITEM NO. \_\_\_\_\_  
 NOTES \_\_\_\_\_  
 MODEL NUMBER: DSA315, DSA322, DSA330, DSA336, DSA354

**DRAWINGS**

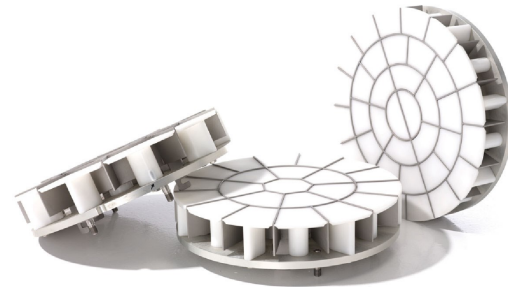
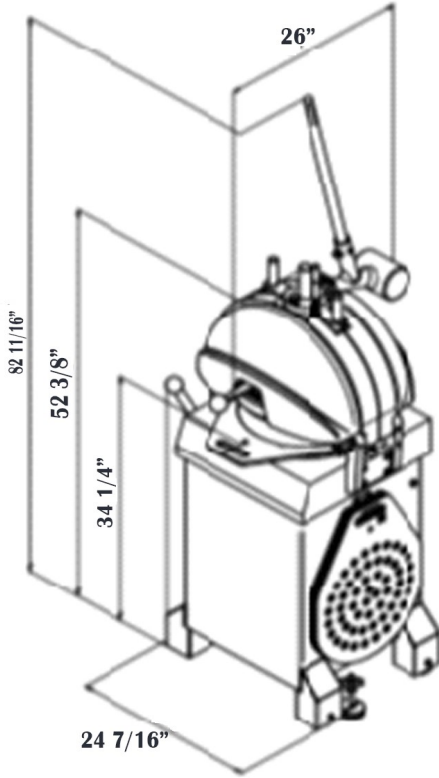

**INTERCHANGEABLE DOUGH PRESS HEADS (DSAHXX)**



**DIVIDER PLATE (FMF3XX)**

Model	Electrical System			
	Volts	Amps	Phases	NEMA
DSA315	120	8	1	5-15P
DSA322	120	8	1	5-15P
DSA330	120	8	1	5-15P
DSA336	120	8	1	5-15P
DSA354	120	8	1	5-15P

**NEMA 5-15P**



Due to periodic changes in designs, methods, procedures, policies and regulations, the specifications contained in this sheet are subject to change without notice. While Doyon exercises good faith efforts to provide information that is accurate, we are not responsible for errors or omissions in information provided or conclusions reached as a result of using these specifications. By using the information provided, the user assumes all risks in connection with such use.

